

1.

4.

- 4.1 SJT-WVF5
 4.2 $(W_m - W_q) / 100$
 4.3 -10 60
 4.4 1T 2T 3T
 4.5 x125%
 4.6 CAN v2.0B
 4.7 15-25VDC
 4.8 200mA

W_m :

W_q :

5.

5.1

5.2

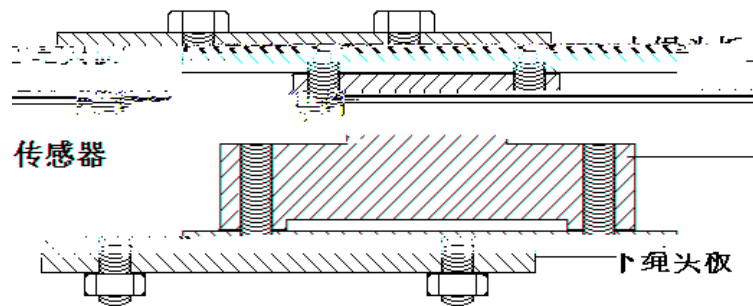

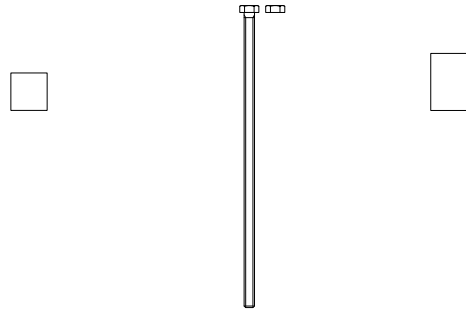

5.2

- a.
- b.
- c.

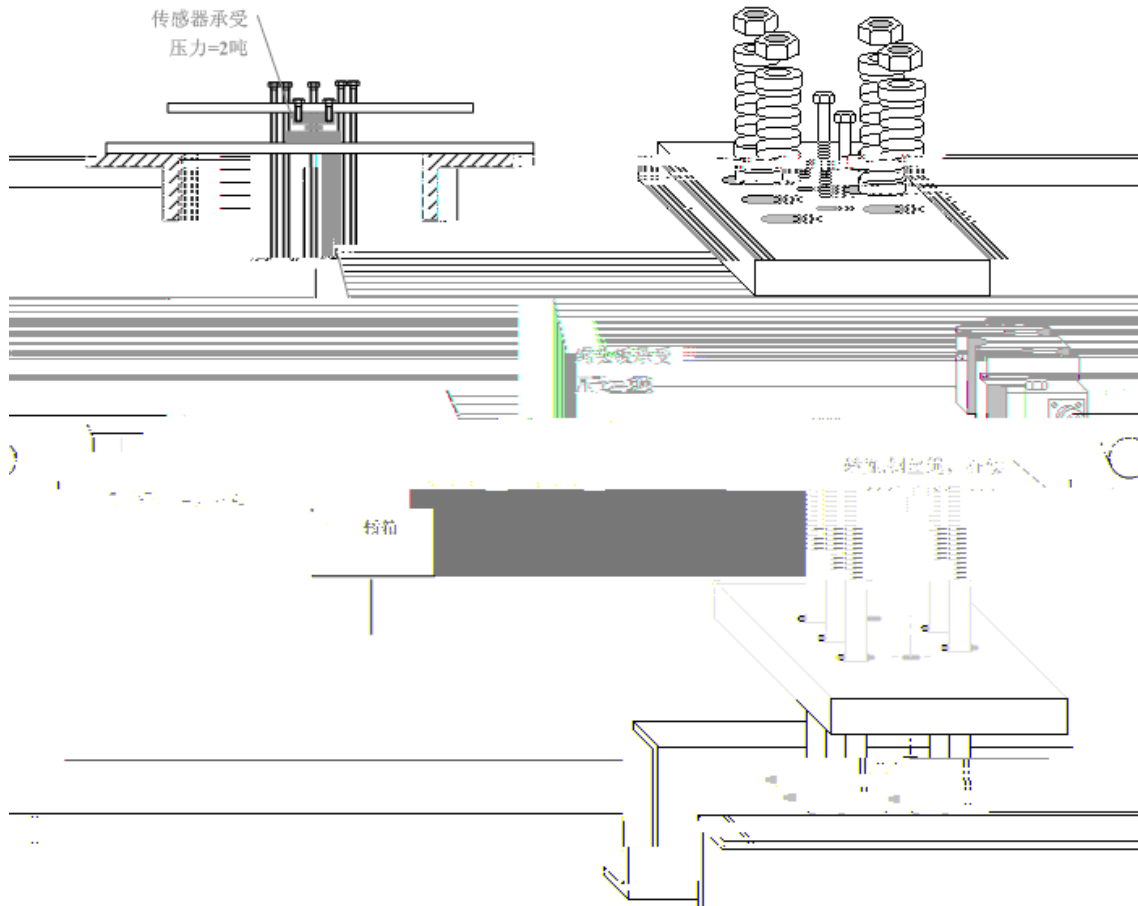

传感器安装方式 (不带支架)

5.3

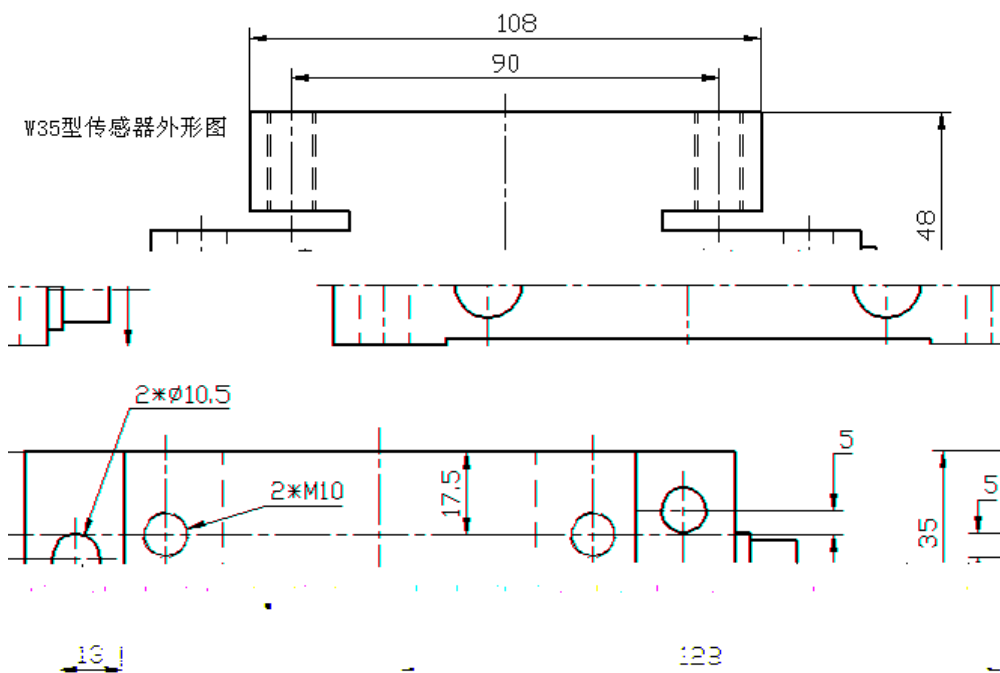

5.4 V35

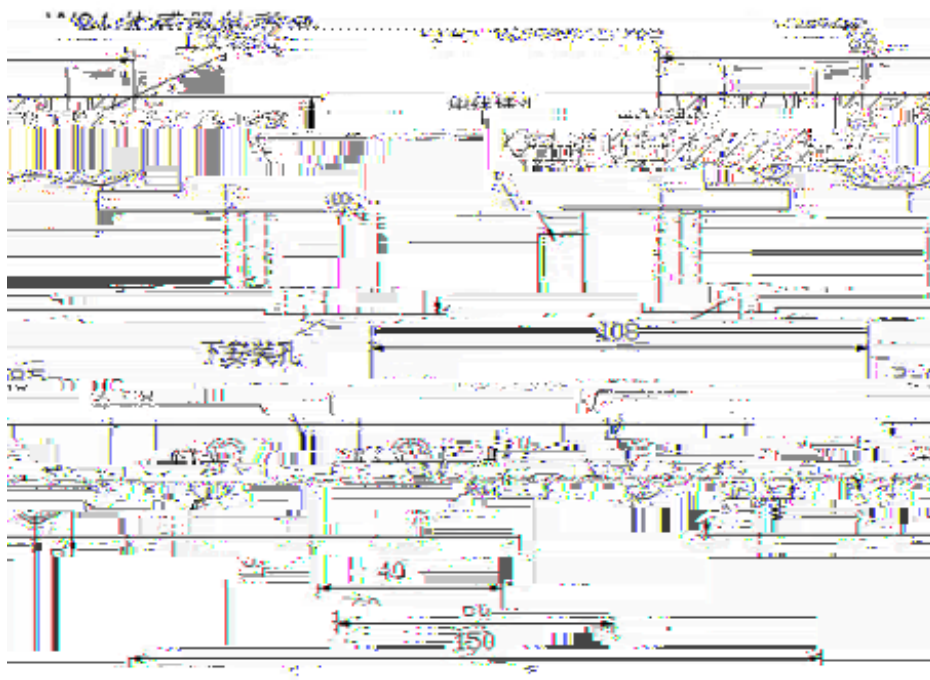

5.5 W24

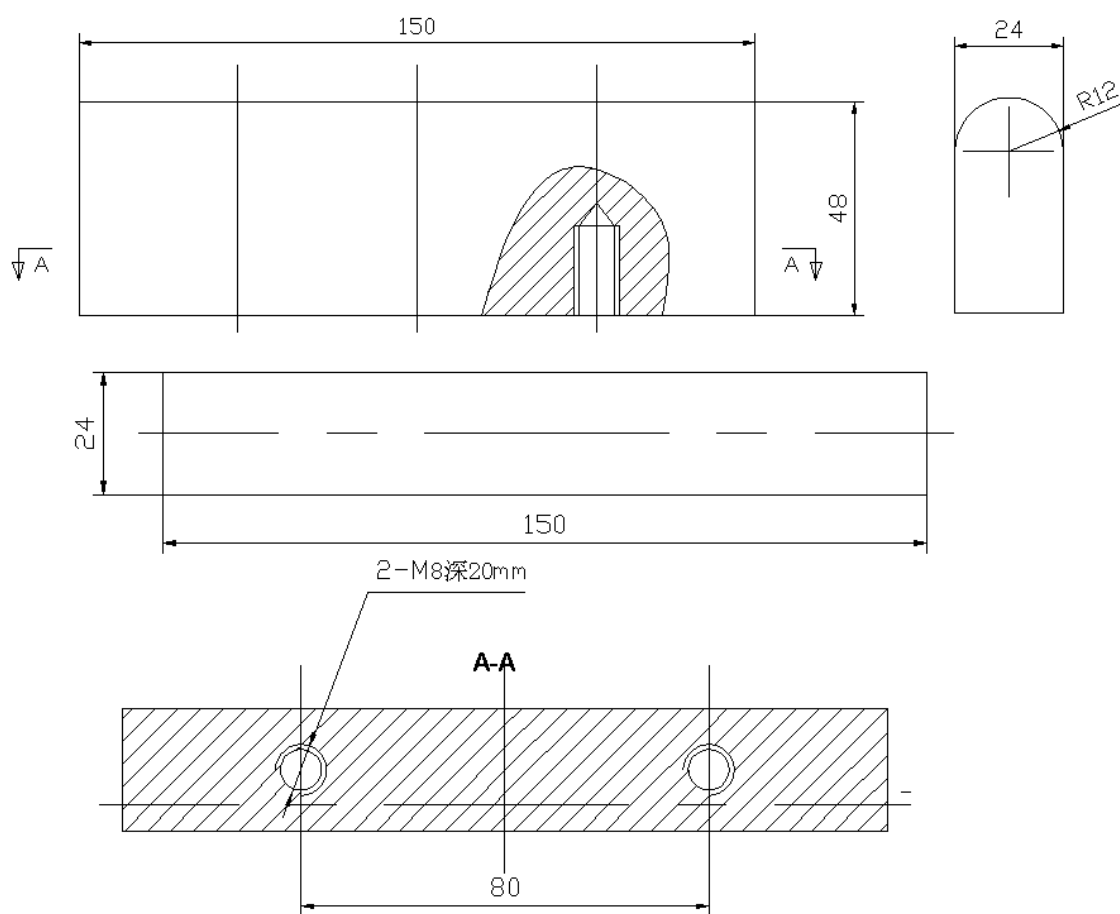

5.6

6.

6.1

10

1 RT+	CAN	C+
2 RT-	CAN	C-
3 +24V	24V	+24V
4 GND	24V	GND
5 AN1+		S+
6 AN1-		S-
7 V+		V+
8 V-		V-
9 AN2+		
10 AN2-		

1

2 100%

3

4

7.2.2

1

2 100%

3

4

5